

Included Components

- A. Hardware X, with Instructions
- B. Canopy
- C. Satellite cable gripper
- D. Center Housing with aircraft cable and coaxial power cable
- E. End Housing with aircraft cable
- F. Light Bar (Hidden behind stone cylinders)
- G. Stone Cylinder
- H. Glass Spacers (Under stone cylinders)

Required Tools

1. #2 Philips screw driver (not provided)
2. Wire cutters/strippers (not provided)
3. Cable cutters (not provided)
4. 2mm Allen Wrench (included)

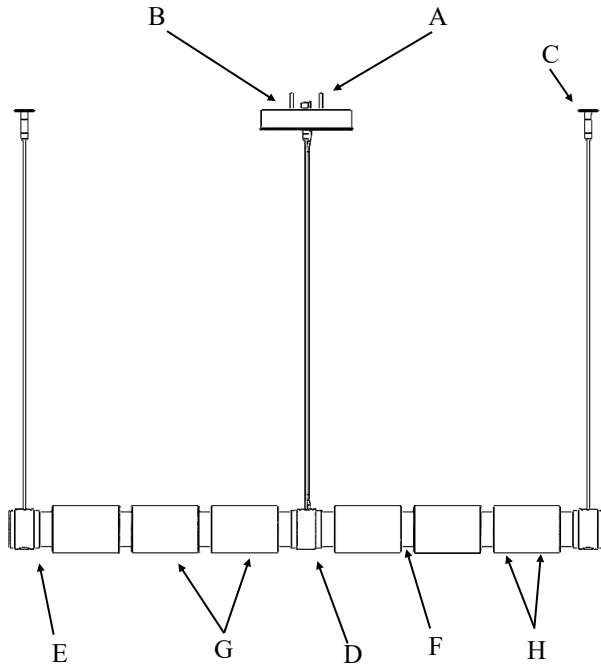

Example Fixture: PLB0089-06

Assembly Instructions

Step 1: Remove the faceplate from Canopy (B) by pulling the faceplate, which is connected by magnets, off of the canopy.

Step 2: Mount Canopy (B) to ceiling using the appropriate Hardware Packet (A) and included instructions.

HARDWARE PACKET X: MOUNTS TO J-BOX

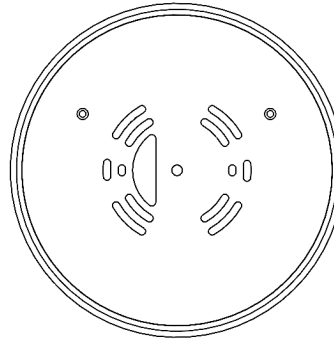

Warning: Source Power should be turned off. Failing to do so may result in damage to the fixture.

Step 3: Make wire connections to source power connecting white wire to white wire (Neutral) and Black wire to Black wire (hot).

Step 4: Run the aircraft cable and coaxial power cable of the Center Housing (D.) through the faceplate then insert the aircraft cable into the canopy cable gripper. Leave the coaxial power cable disconnected for now.

Step 5: Measure out 35" from the center of the J-box in both directions. This is the mounting location for the Satellite cable grippers. Use the EZ toggle from the hardware pack to mount these.

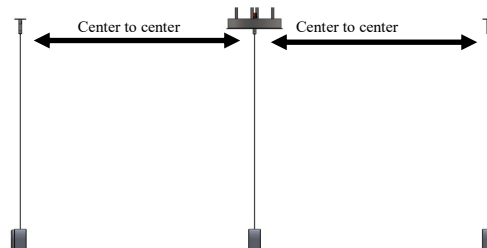

Step 5: Once the mounting location is identified screw the provided toggle bolt body into the drywall using a #2 Philips head screw driver. Once the toggle bolt body is in place, run the provided toggle bolt screw through the satellite cable gripper then screw into the toggle bolt body until it is secured firmly in place. Repeat for the other side.

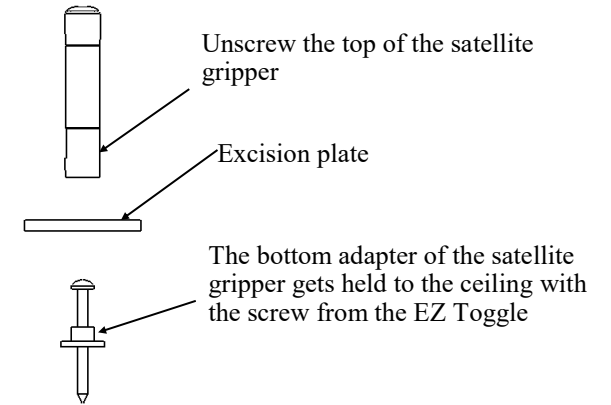

Step 6: Connect the end housings to the cable grippers by inserting the aircraft cable into the cable gripper. Adjust all three housings to the desired height by pushing the aircraft cable further into the gripper. They should all be at the same height

Note: If the aircraft cable is pushed too far into the gripper push up on the gripper to release tension on the cable and pull back through the gripper.

Step 7: Remove the light bar end from one side by unscrewing the three countersunk screws. DO NOT discard gasket.

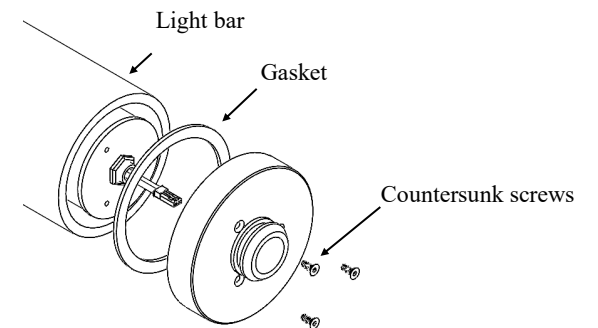

Step 8: With the end of the light bar removed, slide 2 stone spacers down the light bar, bringing them 3/4 down the light bar. Then slide a stone cylinder down to the 3/4 mark and rest it on a pair of stone spacers, evenly spaced beneath the stone. Repeat on the opposing light bar before adding a second stone to either bar. Repeat, alternating sets of 2 spacers and a cylinder, at the 1/2 and 1/4 marks along each light bar. Replace end gasket and end cap.

Note: do not over tighten the 3 small screws that hole the end cap onto the light bar

Step 9: Make sure the spring plungers on both the center and end housings have only the silver detent shown. If you see threads, back this out using the 1/16" Allen Wrench until only the detent is shown.

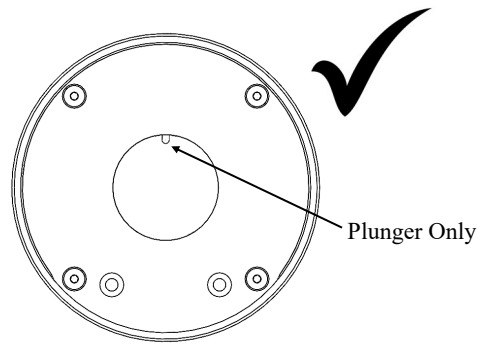
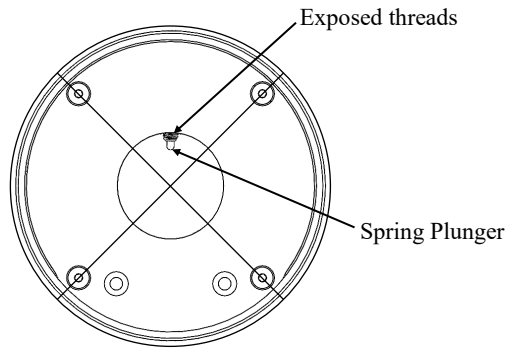

Step 10: Bring the assembled light bar up to the end housing and make the electrical connection by plugging in the male end of the red connector to the female end. Once the electrical connection is made push wires into the end housing

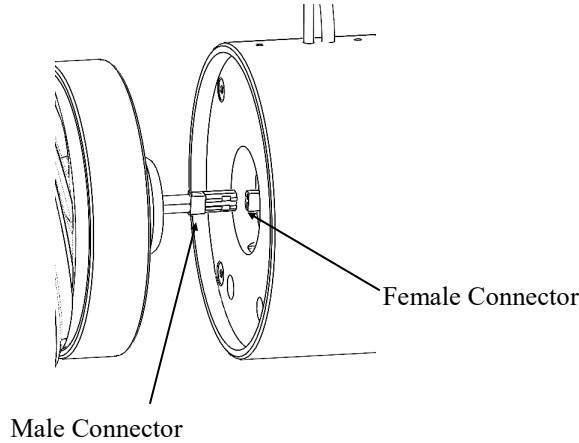

Step 11: Push the lightbar end into the end housing until you can hear the detent snap into place. Repeat this for the center housing then for the other side. Make any final adjustments to ensure the lightbars are level then use cable grippers to snip off any excess aircraft cable. Use the provided 2mm Allen wrench to tighten all connections.

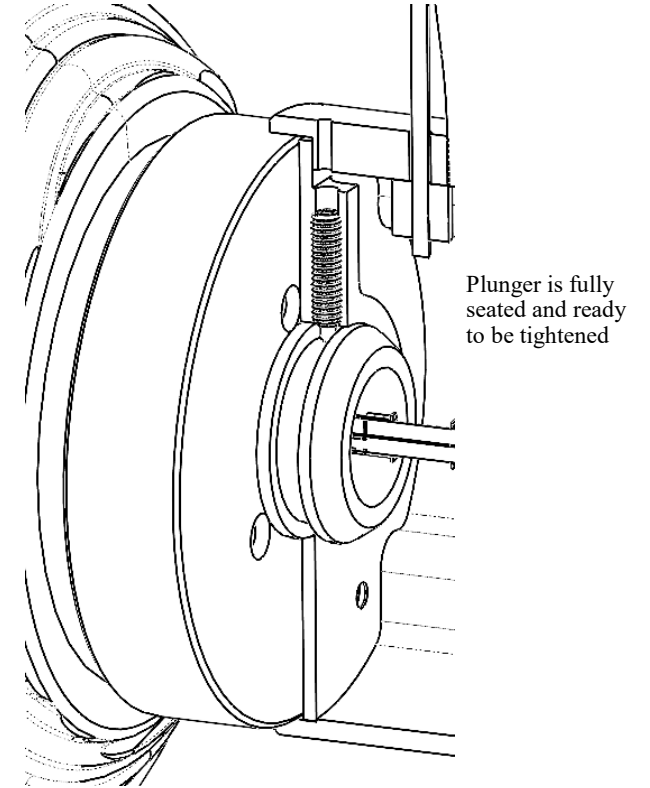

Step 9 Continued

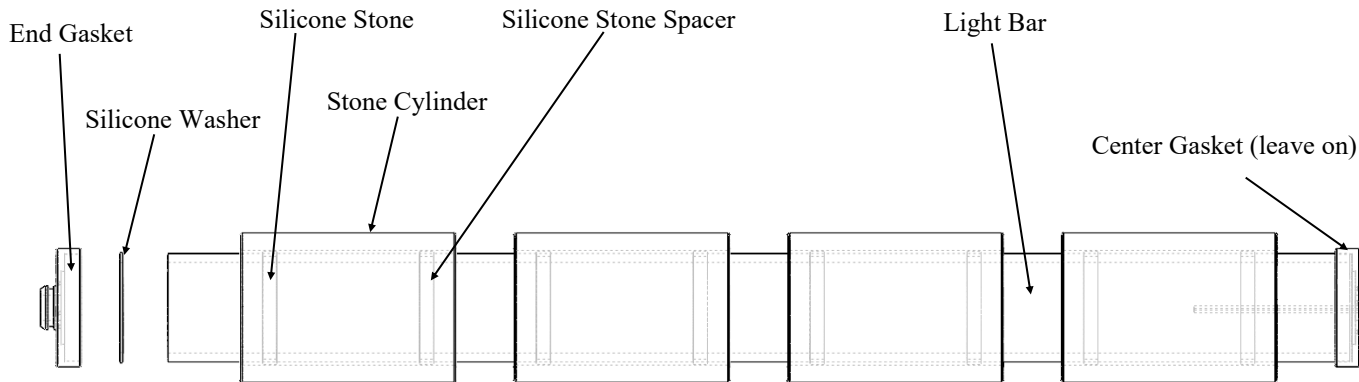

Step 12: Finally, snip the coaxial wire to the appropriate length and make electrical connections by stripping back the clear wire sheath exposing the outer wire. Pull the wire away from the inner wire and twist together making a wire that can be placed into the provided wire nut. Now strip the plastic sheath off the center wire exposing the positive wire. Connect the center wire to the Red (+) wire on the driver and the outer wire to the Blue (-) wire on the driver. Place the cover back onto the canopy then use the provided plastic clips to connect the coaxial power wire to the aircraft cable clipping them on every foot approximately.

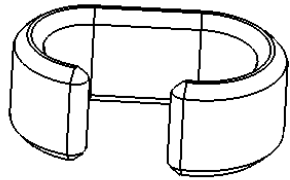

Clear Cable Clip for wire management

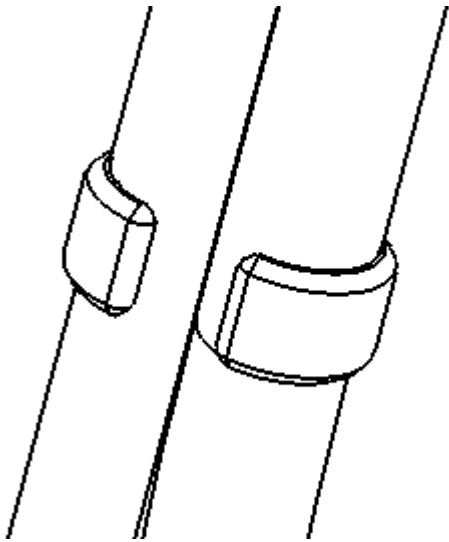

Install Cable clip on coax wire first then clip to the aircraft cable

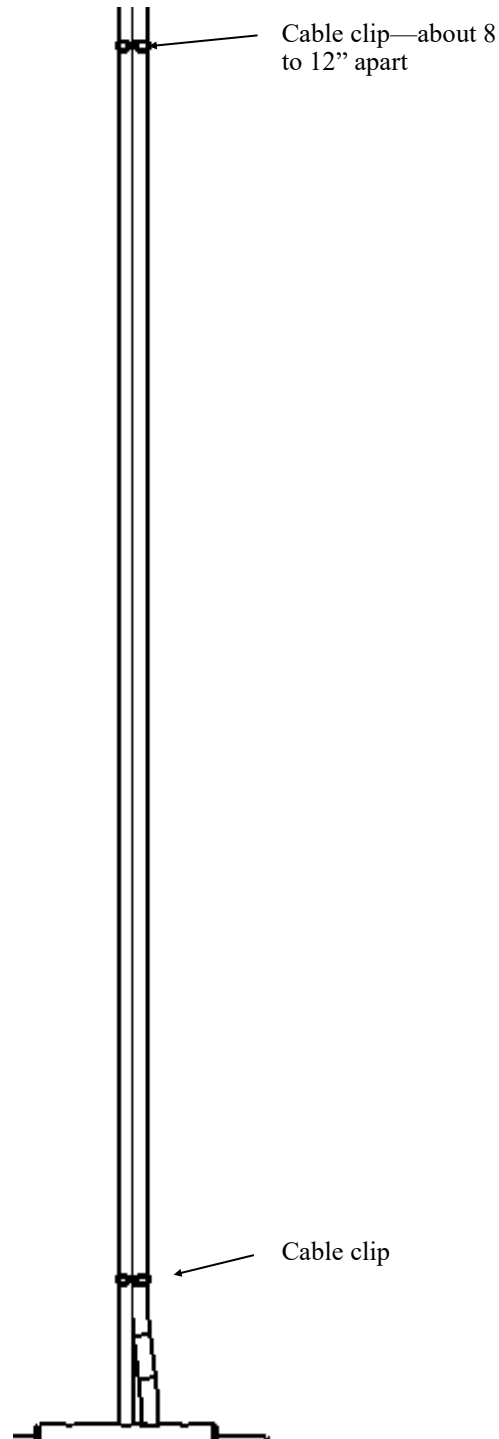

About Hammerton Studio

HAMMERTON STUDIO

When we introduced the Hammerton Studio brand in 2014, we saw an enormous opportunity to raise the bar in decorative lighting. In design, we wanted to lead rather than follow. In construction, we wanted to showcase Hammerton's renowned reverence for time-honored artisan craftsmanship and authentic materials. In performance, we wanted to provide highly reliable solutions that far exceeded industry norms for aesthetics, function, and quality. Based on the brand's dramatic growth and customer feedback, it's clear we are on the right track.

EXTRAORDINARY DESIGN VALUE IN ARTISAN GLASS & METALWORK

Hammerton began in 1995 as a blacksmith shop, but we've come a long way since then. Today we employ a world class team of metal artisans who are disciplined in a broad range of fabrication techniques and processes. We've also added in-house capabilities in blown, cast and kiln-fused glass, and today Hammerton operates one of the largest artisan glass production facilities in the U.S. With deep design and fabrication expertise at the intersection of glass and metalwork, we're laying the foundation for a new era of lighting innovation.

THE HAMMERTON HERITAGE

Our Hammerton Studio brand stands on the shoulders of more than a quarter century of experience pushing the boundaries of innovative custom lighting design. Each Hammerton Studio collection has been inspired by custom work our company has brought to life in collaboration with leading interior design professionals over the years. Built to your specifications, every fixture reflects the uncompromising design and attention to detail that is distinctly Hammerton.

A REPUTATION REFLECTED BY OUR CLIENTS

Hammerton fixtures are as extraordinary as the clients who purchase them, including Forbes 400 members, Fortune 500 leaders, award-winning entertainers, fashion and interior designers, sports legends, and leading luxury hospitality brands.

Hammerton Inc.
217 Wright Brothers Drive
Salt Lake City, UT 84116

801-973-8095 EXT: 4

www.hammerton.com

Warranty

ONE YEAR LIMITED WARRANTY

Hammerton, Inc. (Hammerton) warrants the original owner that this product will be free of defects in material or workmanship for the period of one year from the date of original purchase from Hammerton, if (i) the allegedly defective product has not been abused, misused or improperly maintained and or repaired during the warranty period, (ii) the defect is not caused by water damage/flooding, fire, explosion, earthquakes or similar phenomenon, and (iii) the defect is not caused by improper installation (unless installed by Hammerton).

In order to obtain warranty service, the user must first complete a warranty claims form. Hammerton will determine if the product will be inspected on site or returned to Hammerton. If after the inspection Hammerton finds that the product is defective as claimed, Hammerton will, at its option, repair or replace the product free of charge, or Hammerton may also agree to outsource necessary repair work locally using local contracted labor. Prior to any outsourcing of repair work regarding this fixture, a Work Authorization Form must be signed by both the client and Hammerton Representative. Failure to do so may result in a denial of reimbursement. Hammerton warrants any replaced or repaired products for ninety days after shipment or through the end of the original warranty period, whichever is longer. All products or parts that are replaced become the property of Hammerton.

No representative or employee of Hammerton is authorized to make any modification or addition to this limited warranty.

TO THE FULL EXTENT ALLOWED BY LAW, THE FOREGOING WARRANTY AND REMEDIES ARE EXCLUSIVE, AND HAMMERTON EXPRESSLY DISCLAIMS ALL OTHER WARRANTIES, EXPRESSED OR IMPLIED, INCLUDING WITHOUT LIMITATION THE IMPLIED WARRANTIES OF MERCHANTABILITY AND FITNESS FOR A PARTICULAR PURPOSE. TO THE FULL EXTENT ALLOWED BY LAW, HAMMERTON EXCLUDES AND DISCLAIMS LIABILITY, WHETHER BASED IN CONTRACT OR TORT (INCLUDING NEGLIGENCE FOR ANY CONSEQUENTIAL, INDIRECT INCIDENTAL OR SPECIAL DAMAGES OF ANY NATURE ARISING OUT OF THE SALE INSTALLATION, MAINTENANCE, USE OR FAILURE OF THIS PRODUCT, EVEN IF HAMMERTON HAS BEEN ADVISED OF THE POSSIBILITY OF SUCH DAMAGES IN ADVANCE, AND HAMMERTON LIMITS ITS LIABILITY TO REPLACEMENT, REPAIR OR REFUND OF THE PURCHASE PRICE PAID, AT HAMMERTON'S OPTION.) SOME STATES DO NOT ALLOW LIMITATIONS ON HOW LONG AN IMPLIED WARRANTY LASTS AND/OR DO NOT ALLOW THE EXCLUSION OR LIMITATION OF INCIDENTAL OR CONSEQUENTIAL DAMAGES, SO THE ABOVE LIMITATION ON IMPLIED WARRANTY AND INCIDENTAL OR CONSEQUENTIAL DAMAGES MAY NOT APPLY TO YOU. THIS WARRANTY GIVES YOU SPECIFIC LEGAL RIGHTS YOU MAY HAVE OTHER RIGHTS, WHICH VARY FROM STATE TO STATE

HAMMERTONSTUDIO™

Assembly Instructions

PLB00XX-04 "Mandrel"

Image below is a representation of applicable product collection

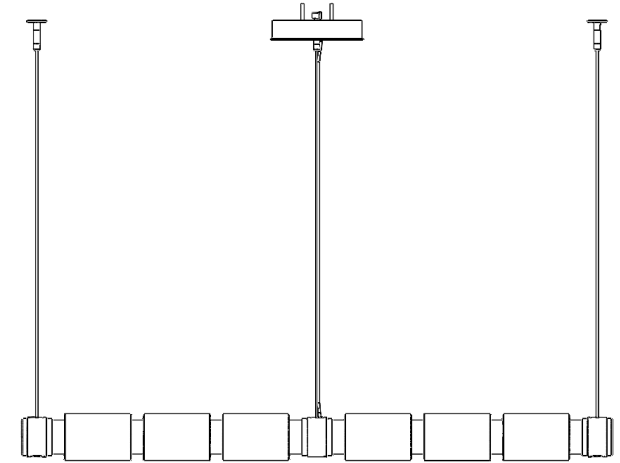

PLB0096-04

WARNING: FAILURE TO INSTALL THIS FIXTURE PROPERLY MAY RESULT IN SERIOUS PERSONAL INJURY OR DEATH AND PROPERTY DAMAGE.

It is recommended that this product be installed by a licensed electrician.

41-001-00278

Rev 1