

**Mounting Detail**  
MOUNTS TO BUILDING STRUCTURE

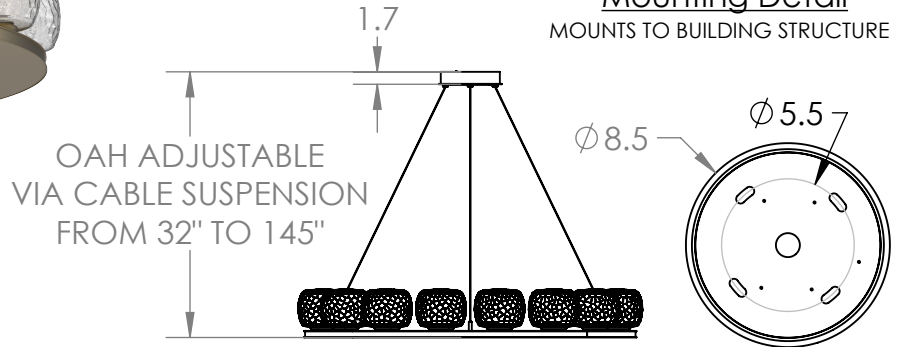

**PRODUCT DESCRIPTION**

A modern fusion of geometric form and organic design, the Vessel Ring Chandelier provides a captivating play of light and shadow that brings visual intrigue and sophistication to today's interiors. Vessel lighting is illuminated with 93+ CRI integrated LED and includes a choice of glass colors, finishes and color temperature options.

**PRODUCT SPECIFICATION**

- Construction: Steel Body and Blown Glass
- Finish Options:  BS  MB  FB  GB  CS  GP  BB  NB  SN  GM  RB  HB
- Glass Options:  A  B  C  S
- Suspension Method: Ceiling Mount
- Weight(lbs.): 82
- UL Rating: Indoor/Dry
- Top Diffuser: Closed Glass
- Bottom Diffuser: Frosted Acrylic
- Light Source: LED
- Electrical Qty: 20
- Wattage (Watts): 42
- Voltage (Volts): 120
- Source Lumens: 3639
- Dimming: Forward/Reverse Phase to 1%
- CCT: 2700k or 3000K
- Driver Quantity & Location: 2, In Canopy
- CRI: 93+
- Power Factor: >0.9

SCAN FOR MORE INFORMATION

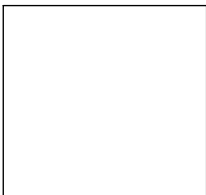

**GENERAL NOTES:**

All dimensions are shown in inches unless otherwise stated.  
 Visit [studio.hammerton.com](http://studio.hammerton.com) to read about our Lifetime Limited Warranty.  
 This product may use mixed materials like steel and aluminum in its construction. Transparent finishes may vary between steel and aluminum.  
 All Hammerton fixtures are handcrafted by artisans. Subtle imperfections reflect the mark of the artisan and should be expected in any handcrafted product. Dimensions may vary up to 7/8".  
 © Copyright 2023. All rights in design, detail or invention of this drawing are reserved as the property of Hammerton. Any imitation or adaptation without written consent is strictly prohibited.  
 Hammerton Inc. 217 Wright Brothers Dr. Salt Lake City, UT 84116 (801)973-8095 | [studio.hammerton.com](http://studio.hammerton.com) | [info@hammerton.com](mailto:info@hammerton.com)