

Collection: UPTOWN MESH

Product #: CHB0019-24-0

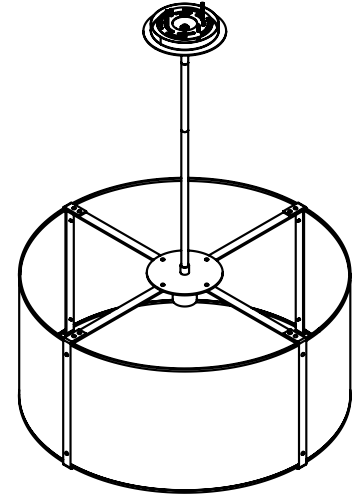

NO LENS, EXPOSED LAMPING

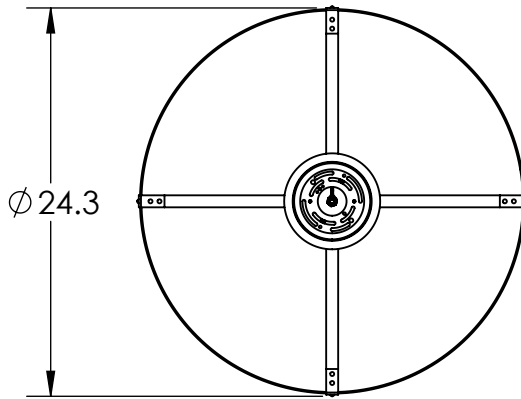
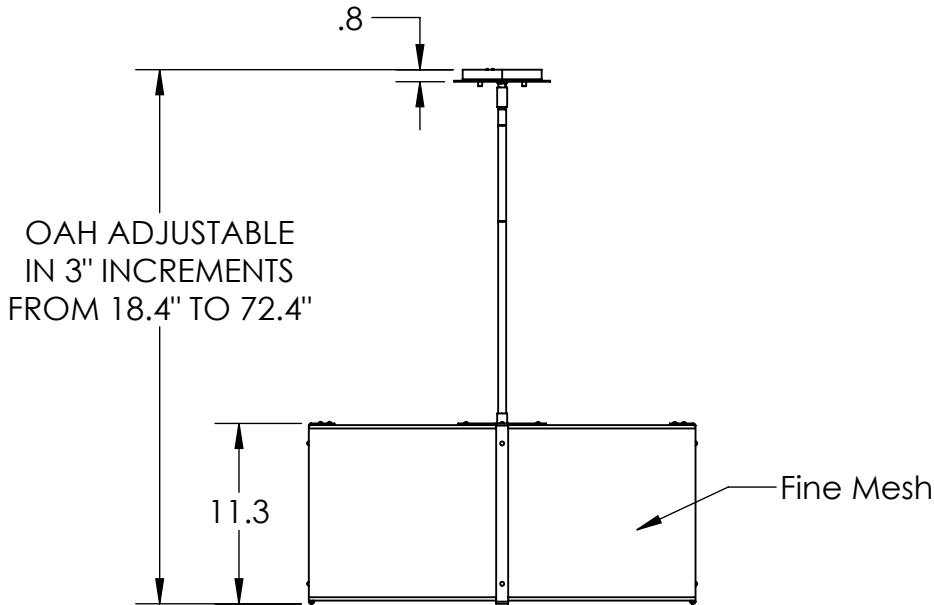

Bulbs Not Included

Visit studio.hammerton.com for product options and specifications.

3/4/2023 (D)

Mounting Packet: Y	Electrical Type:
Approximate lbs.: 13	Bulb Qty: 1 Bulb Type: A19
Finish: SEE WEB SITE FOR OPTIONS	Wattage: 100 Voltage: 120
Top Diffuser: OPEN	Socket Type: E26
Bottom Diffuser: OPEN	UL Location: DRY

Mounting Detail

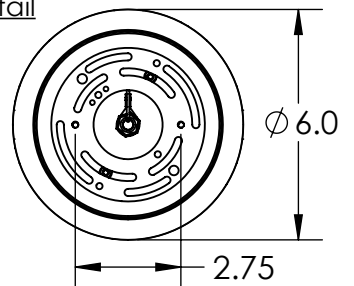

MOUNTS DIRECTLY TO J-BOX

All fixtures created by Hammerton are handcrafted by artisans. Dimensions may vary up to 7/8".

© Copyright 2016. All rights in design, detail or invention of this drawing are reserved as the property of Hammerton. Any imitation or adaptation without written consent is strictly prohibited.

Hammerton Inc. 217 Wright Brothers Dr. Salt Lake City, UT 84116 (801)973-8095