

HAMMERTONSTUDIO™

Assembly Instructions

GEM PENDANT

LAB0039-01



SCAN FOR VIDEO
INSTRUCTIONS

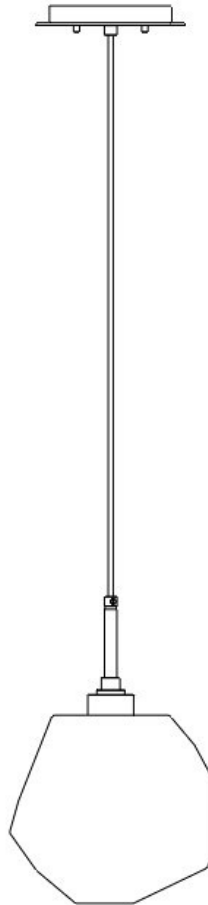

WARNING: FAILURE TO INSTALL THIS FIXTURE PROPERLY MAY RESULT IN SERIOUS PERSONAL INJURY OR DEATH AND PROPERTY DAMAGE.

It is recommended that this product be installed by a licensed electrician who is familiar with proper LED installation and electrical loads.

41-001-00190
Rev 1

Required Tools

1. Philips screw driver (not provided)
2. Wire cutters/strippers (not provided)
3. Measuring tape (not provided)
4. Flat blade screw driver (not provided)

Included Components

- A. LED Driver
- B. Hardware Packet Y, with Instructions
- C. Canopy
- D. Cord grip (attached to canopy)
- E. Pendant assembly
- F. #4-40 Flathead screws (QTY: 2)
- G. Blown Glass

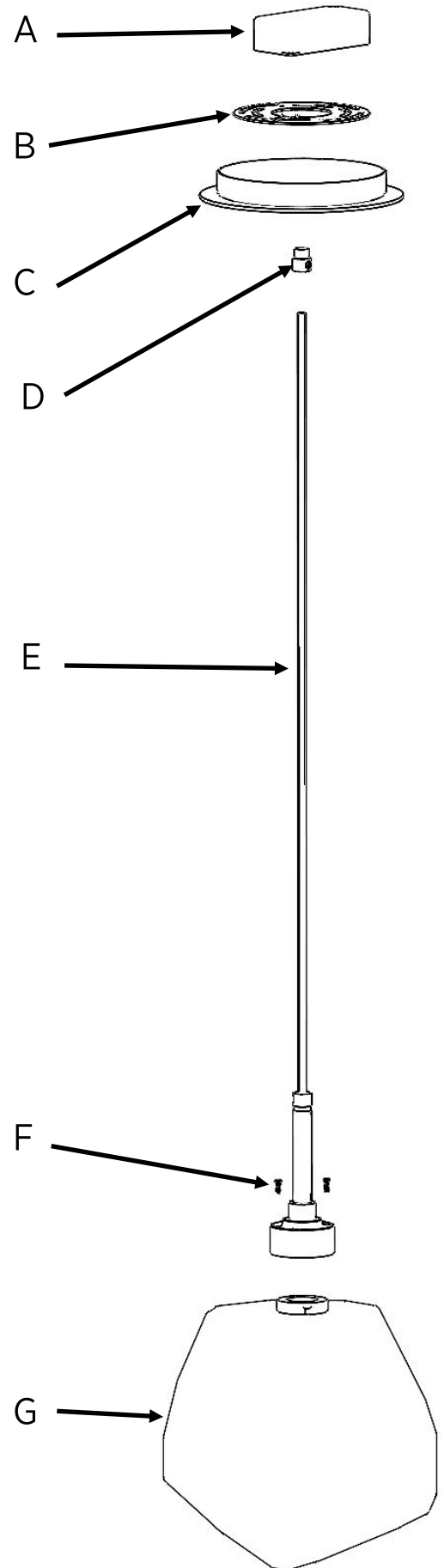

IMPORTANT

DRIVER TO BE INSTALLED IN J-BOX.
MINIMUM SIZE OF J-BOX REQUIRED IS
4" L x 4" W x 1.5" H

ASSEMBLY

Step 1

TURN OFF POWER TO JUNCTION BOX TO BE USED FOR INSTALLATION.

Step 2

Connect the **WHITE** wire from the LED Driver to the **WHITE** wire from the power source inside the J-Box using one of the provided Orange wire nuts. Follow the same steps for the two **BLACK** wires.

WARNING

THE **BLUE** AND **RED** LEADS FROM THE DRIVER ARE FOR DC CURRENT ONLY. IF THESE LEADS OR THE LED PENDANTS ARE CONNECTED TO AC POWER THE FIXTURE WILL BE DAMAGED.

Step 3

Mount the driver to the top of the universal plate provided in the mounting packet using the double sided tape pre-attached to the driver. Then affix the universal plate to the J-Box using the 1.5" L #8-32 screws provided in the mounting pack. The **Blue, Red, Pink, and Purple** wires should **NOT** be connected at this point. (LED Driver will sit inside of J-Box)

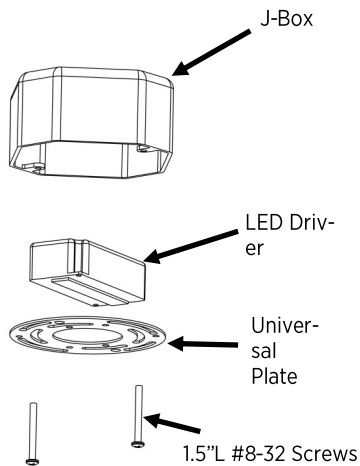

Step 4

- 1) Feed exposed wire end of pendant assembly up through the cord grip on the canopy until the desired length of cord is left between the canopy and light body.
- 2) Using a flat blade screw driver tighten the cord grip to secure pendant. DO NOT OVER TIGHTEN. THIS MAY DAMAGE THE FIXTURE.
- 3) Using wire cutters/strippers trim excess cord. (Take into account a minimum of 6" of cord will be required for making the wire connections in the J-Box)

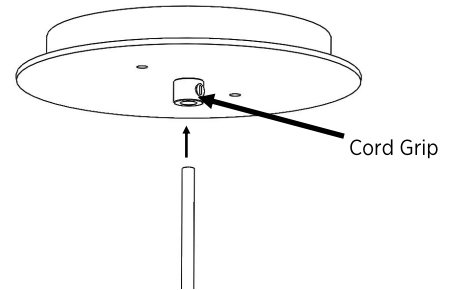

Step 5

Make wire connections from the Pendant assembly to the LED Driver. The Pendant will have a **WHITE** and **BLACK** wire and the LED Driver will have a **RED** and **BLUE** wire.

- 1) Connect the **WHITE** wire from the pendant assembly to the **RED** wire of the LED Driver using one of the provided Orange wire nuts.
- 2) Connect the **BLACK** wire from the pendant assembly to the **BLUE** wire (right next to the red wire) of the LED Driver using one of the provided Orange wire nuts.

NOTE: The **PINK** and **PURPLE** wires are used for optional 0-10V dimming. If not applicable, cap each of the wires.

Step 6

Mount the canopy to the ceiling using the **Mounting Instructions** provided within Hardware Pack Y.

Step 7

Attach the glass to the LED pendant housing using the provided #4-40 flathead screws and a Philips screw driver.

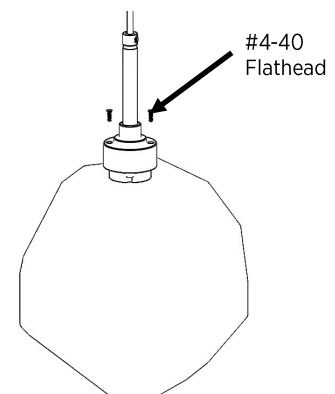

Warranty

ONE YEAR LIMITED WARRANTY

Hammerton, Inc. (Hammerton) warrants the original owner that this product will be free of defects in material or workmanship for the period of one year from the date of original purchase from Hammerton, if (i) the allegedly defective product has not been abused, misused or improperly maintained and or repaired during the warranty period, (ii) the defect is not caused by water damage/flooding, fire, explosion, earthquakes or similar phenomenon, and (iii) the defect is not caused by improper installation (unless installed by Hammerton).

In order to obtain warranty service, the user must first complete a warranty claims form. Hammerton will determine if the product will be inspected on site or returned to Hammerton. If after the inspection Hammerton finds that the product is defective as claimed, Hammerton will, at its option, repair or replace the product free of charge, or Hammerton may also agree to outsource necessary repair work locally using local contracted labor. Prior to any outsourcing of repair work regarding this fixture, a Work Authorization Form must be signed by both the client and Hammerton Representative. Failure to do so may result in a denial of reimbursement. Hammerton warrants any replaced or repaired products for ninety days after shipment or through the end of the original warranty period, whichever is longer. All products or parts that are replaced become the property of Hammerton.

No representative or employee of Hammerton is authorized to make any modification or addition to this limited warranty.

TO THE FULL EXTENT ALLOWED BY LAW, THE FOREGOING WARRANTY AND REMEDIES ARE EXCLUSIVE, AND HAMMERTON EXPRESSLY DISCLAIMS ALL OTHER WARRANTIES, EXPRESSED OR IMPLIED, INCLUDING WITHOUT LIMITATION THE IMPLIED WARRANTIES OF MERCHANTABILITY AND FITNESS FOR A PARTICULAR PURPOSE. TO THE FULL EXTENT ALLOWED BY LAW, HAMMERTON EXCLUDES AND DISCLAIMS LIABILITY, WHETHER BASED IN CONTRACT OR TORT (INCLUDING NEGLIGENCE FOR ANY CONSEQUENTIAL, INDIRECT INCIDENTAL OR SPECIAL DAMAGES OF ANY NATURE ARISING OUT OF THE SALE INSTALLATION, MAINTENANCE, USE OR FAILURE OF THIS PRODUCT, EVEN IF HAMMERTON HAS BEEN ADVISED OF THE POSSIBILITY OF SUCH DAMAGES IN ADVANCE, AND HAMMERTON LIMITS ITS LIABILITY TO REPLACEMENT, REPAIR OR REFUND OF THE PURCHASE PRICE PAID, AT HAMMERTON'S OPTION.)

SOME STATES DO NOT ALLOW LIMITATIONS ON HOW LONG AN IMPLIED WARRANTY LASTS AND/OR DO NOT ALLOW THE EXCLUSION OR LIMITATION OF INCIDENTAL OR CONSEQUENTIAL DAMAGES, SO THE ABOVE LIMITATION ON IMPLIED WARRANTY AND INCIDENTAL OR CONSEQUENTIAL DAMAGES MAY NOT APPLY TO YOU. THIS WARRANTY GIVES YOU SPECIFIC LEGAL RIGHTS YOU MAY HAVE OTHER RIGHTS, WHICH VARY FROM STATE TO STATE

About Hammerton Studio

HAMMERTON STUDIO

When we introduced the Hammerton Studio brand in 2014, we saw an enormous opportunity to raise the bar in decorative lighting. In design, we wanted to lead rather than follow. In construction, we wanted to showcase Hammerton's renowned reverence for time-honored artisan craftsmanship and authentic materials. In performance, we wanted to provide highly reliable solutions that far exceeded industry norms for aesthetics, function, and quality. Based on the brand's dramatic growth and customer feedback, it's clear we are on the right track.

EXTRAORDINARY DESIGN VALUE IN ARTISAN GLASS & METALWORK

Hammerton began in 1995 as a blacksmith shop, but we've come a long way since then. Today we employ a world class team of metal artisans who are disciplined in a broad range of fabrication techniques and processes. We've also added in-house capabilities in blown, cast and kiln-fused glass, and today Hammerton operates one of the largest artisan glass production facilities in the U.S. With deep design and fabrication expertise at the intersection of glass and metalwork, we're laying the foundation for a new era of lighting innovation.

THE HAMMERTON HERITAGE

Our Hammerton Studio brand stands on the shoulders of more than a quarter century of experience pushing the boundaries of innovative custom lighting design. Each Hammerton Studio collection has been inspired by custom work our company has brought to life in collaboration with leading interior design professionals over the years. Built to your specifications, every fixture reflects the uncompromising design and attention to detail that is distinctly Hammerton.

A REPUTATION REFLECTED BY OUR CLIENTS

Hammerton fixtures are as extraordinary as the clients who purchase them, including Forbes 400 members, Fortune 500 leaders, award-winning entertainers, fashion and interior designers, sports legends, and leading luxury hospitality brands.

Hammerton Inc.
217 Wright Brothers Drive
Salt Lake City, UT 84116

801-973-8095 EXT: 4
www.hammerton.com