

Collection: PARALLEL

Product #: CHB0042-2B

REVISIONS		
REV.	DESCRIPTION	Drawn
A	CREATED	C. N.

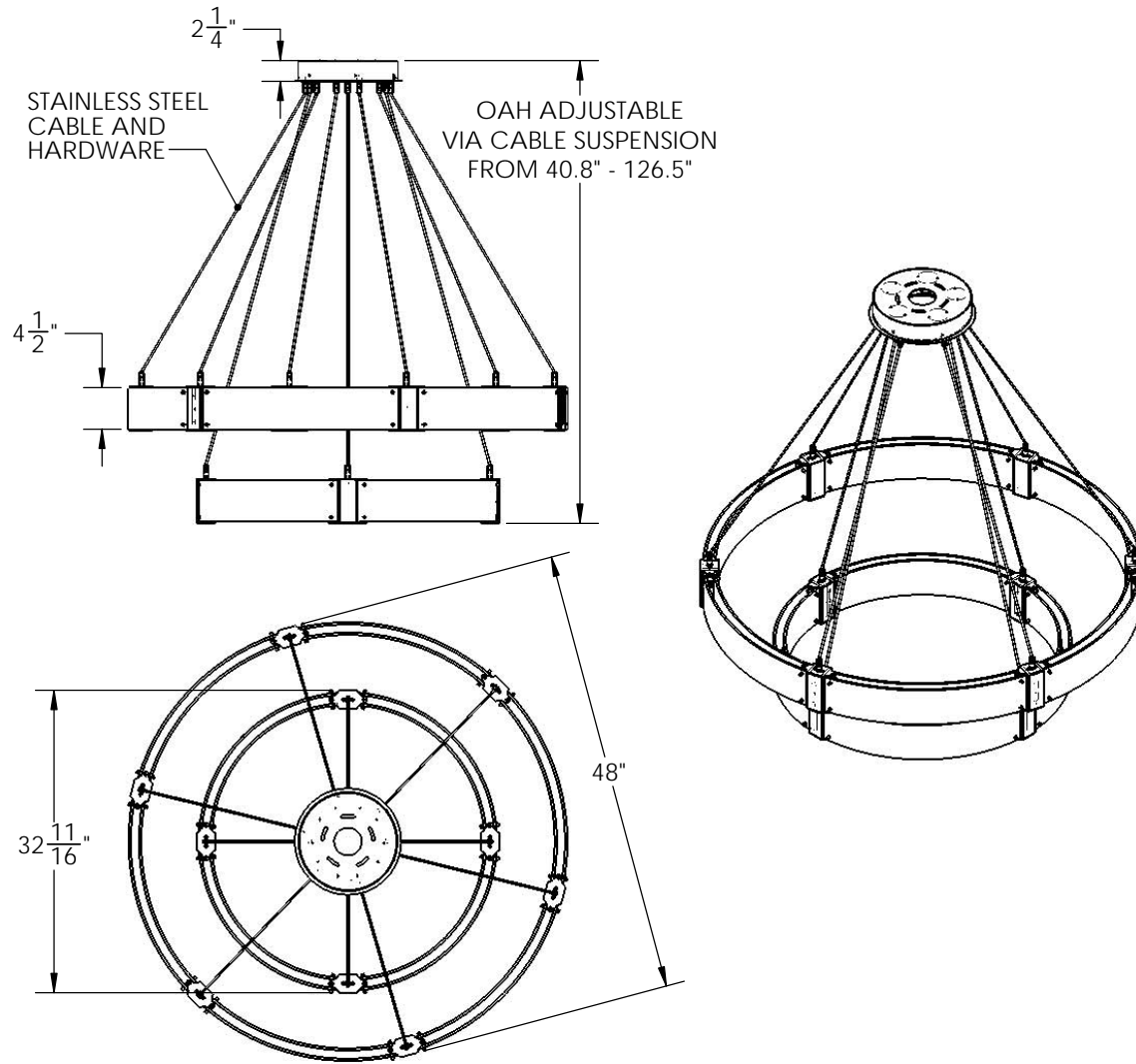

Visit [hammertonstudio.com](http://hammertonstudio.com) for product options and specifications.

4/19/2022 ©

Mounting Packet: Z	Weight(lbs.): 65	Electrical Type: LED	CCT: 2700/3000 K
UL Location: DRY		Elec. Qty: 30	Wattage: 78
Finish: SEE WEB SITE FOR OPTIONS		Voltage: 120	
Top Diffuser: CLOSED		Lumens: Ambient: 4664	Down: 2332
Bottom Diffuser: FROSTED GLASS		Dimmable: Forward/Reverse Phase to 1%	
		CRI: 93+	Power Factor: >0.9
All fixtures created by Hammerton are handcrafted by artisans. Dimensions may vary up to 7/8".			
© Copyright 2021. All rights in design, detail or invention of this drawing are reserved as the property of Hammerton. Any imitation or adaptation without written consent is strictly prohibited.			
Hammerton Inc. 217 Wright Brothers Dr. Salt Lake City, UT 84116 (801)973-8095			

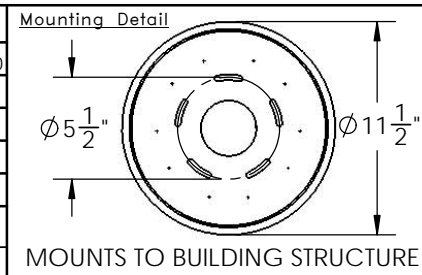

MOUNTS TO J-BOX AND CEILING  
MOUNTS DIRECTLY TO J-BOX