

Included Components

- | | |
|--|--|
| A. Hardware Packet N | H. Cup Motif |
| 1. Steel Set Screw (QTY:1) | I. Fixture Mount |
| 2. Wire Nuts (QTY:3) | J. Ground Wire |
| B. Inner Box | K. 2" IP |
| C. Outer Box | L. IP Nut |
| D. LED Assembly | M. 3/8" 8-32 Set Screw(Qty:2) |
| E. Frosted Glass Panes (Qty:4) | N. Lens Retention Bars (Qty: 4) |
| F. 2" #8-32 Flat Head Screws (Qty:4) | O. 5/16" #8-32 Flat Head Screws (Qty: 4) |
| G. 1/4" #8-32 Flat Head Screws (Qty:4) | |

Required Tools

1. Philips screw driver (not provided)
2. Wire cutters/strippers (not provided)
3. Allen Key
4. Wrench (not provided)

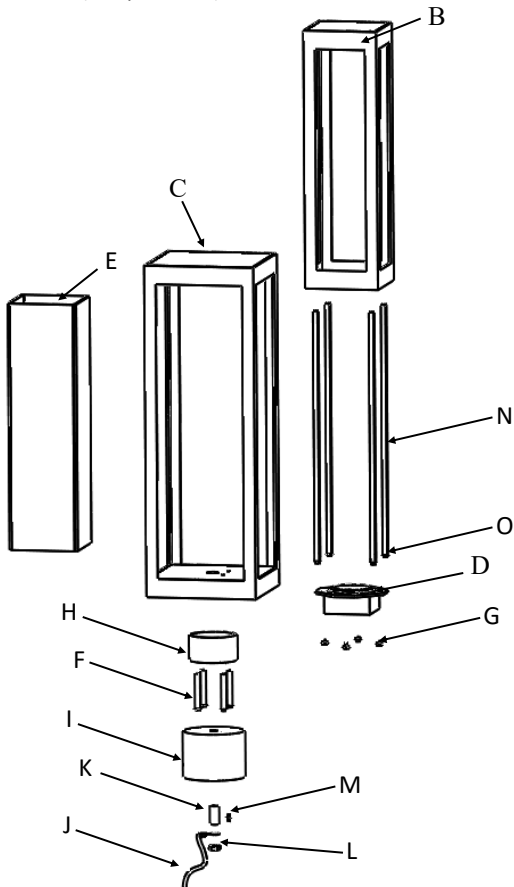

Assembly Instructions

Step 1: Install Fixture Glass.

- i. Flip Inner Box Assembly upside down.
- ii. Remove the LED Assembly by unscrewing the 1/4" #8-32 Flat Head Screws (G).
- iii. Remove Lens Retention bars (N) by unscrewing the 5/16" #8-32 Flat Head Screws (O).
- iv. Slide two Frosted Glass Panes (E) into the fixture through the center hole in the bottom of the box with the glossy surface facing outward.

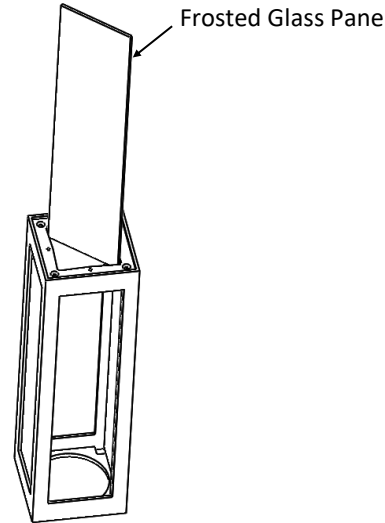

- iv. Place one Lens Retention Bar (N) through the center hole and into the notch in the top of the box with the foam tape touching each piece of glass.
- v. Repeat the process for the other pieces of glass.

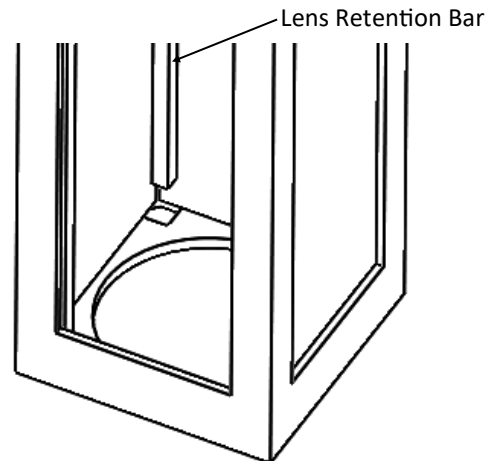

- v. Screw the Lens Retention Bars (N) into the base of the Inner Box using the 5/16" #8-32 Flat Head Screws (O) ensuring the foam stays against the glass.

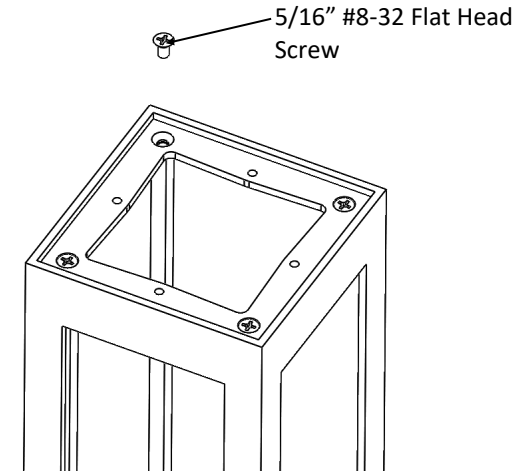

- vi. Secure the LED Assembly to Inner Box with four 1/4" Painted 8-32 Flat Head Screws.

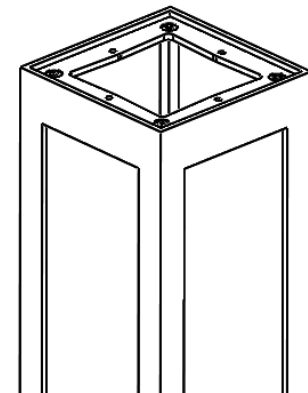
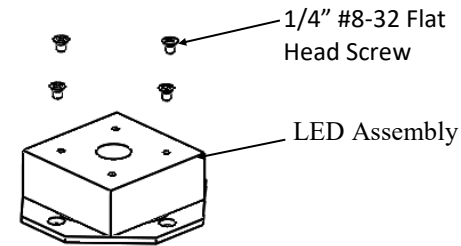

Step 2: Assemble Inner and Outer Boxes.

Feed wires through cup motif. Secure Inner Box, Outer Box, and Cup Motif together with four 2" 8-32 Flat Head Screws.

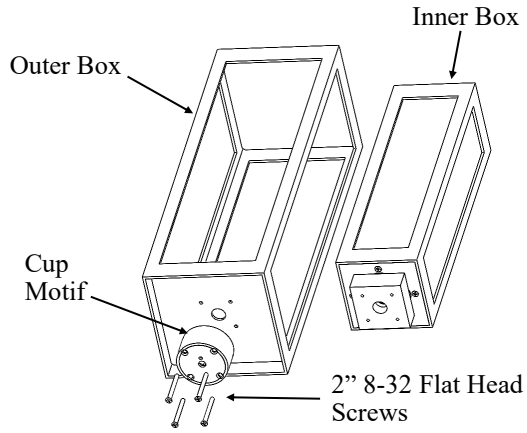

Step 3: Install Mounting Cup.

Screw 3/8" long Set Screw halfway into Cup Motif at the bottom of the Fixture. Route the Fixture's wires through the Fixture Mount, the IP, the Ground Wire terminal, and IP Nut. Screw IP halfway into Cup Motif. Align Fixture Mount to Cup Motif with IP and Set Screw. Slide Ground Wire over IP and secure Ground Wire and Fixture Mount with IP Nut.

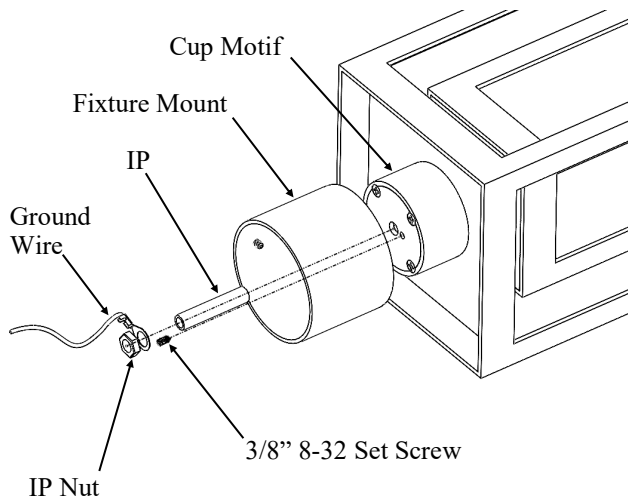

Step 4: Make electrical connections between the fixture and power supply.

Step 5: Install the fixture to the post by tightening the set screw provided

WARNING: Sealant must be applied around the bottom of the fixture for weatherproofing

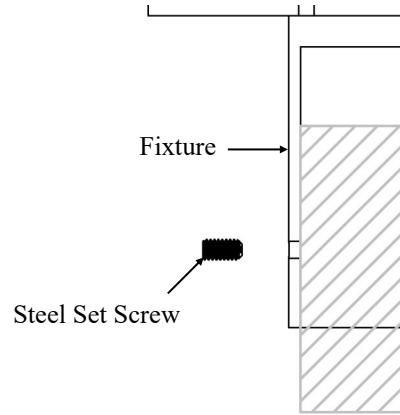

About Hammerton Studio

HAMMERTON STUDIO

In 2013, the Hammerton Studio brand was created to offer artisan-crafted, contemporary design solutions that are both versatile and accessible. Hammerton Studio fixtures add contemporary distinction to entries, great rooms and master suites, yet are cost-effective enough to use throughout any residential or commercial projects. Like all Hammerton fixtures, they are designed and fabricated in Salt Lake City, Utah using domestically sourced materials.

POWERFUL DESIGN

Since 1992, Hammerton has been known for extraordinary decorative lighting that is boldly designed, expertly rendered, perfectly proportioned and exquisitely detailed. Each fixture exudes a design aesthetic that is timeless and enduring, yet remarkably relevant.

UNCOMPROMISING CRAFTSMANSHIP

In addition to their exceptional metalworking and finishing expertise, Hammerton artisans share an aesthetic eye and a sculptural talent that define the difference between ordinary and extraordinary craftsmanship. Every fixture demonstrates its artisan's ability to elevate craft to an art form.

UNIQUE MATERIALS

Hammerton's recent acquisition of the Lightspann brand has added unparalleled strength in all types of artisan glass, including hand-blown, slumped, fused, and lampworked glass. The combination of Hammerton's traditional metalworking and Lightspann glass allows steel, woven mesh, fabric and glass to be combined in a manner which cannot be duplicated

A REPUTATION REFLECTED BY OUR CLIENTS

Hammerton fixtures are as extraordinary as the clients who purchase them, including Forbes 400 members, Fortune 500 leaders, award-winning entertainers, fashion and interior designers, sports legends, and leading luxury hospitality brands.

Hammerton
217 Wright Brothers Drive
Salt Lake City, UT
84116

801-973-8095 EXT: 4
www.hammerton.com

Warranty

ONE YEAR LIMITED WARRANTY

Hammerton, Inc. (Hammerton) warrants the original owner that this product will be free of defects in material or workmanship for the period of one year from the date of original purchase from Hammerton, if (i) the allegedly defective product has not been abused, misused or improperly maintained and or repaired during the warranty period, (ii) the defect is not caused by water damage/flooding, fire, explosion, earthquakes or similar phenomenon, and (iii) the defect is not caused by improper installation (unless installed by Hammerton).

In order to obtain warranty service, the user must first complete a warranty claims form. Hammerton will determine if the product will be inspected on site or returned to Hammerton. If after the inspection Hammerton finds that the product is defective as claimed, Hammerton will, at its option, repair or replace the product free of charge, or Hammerton may in its sole discretion, refund the purchase price. Hammerton warrants any replaced or repaired products for ninety days after shipment or through the end of the original warranty period, whichever is longer. All products or parts that are replaced become the property of Hammerton.

No representative or employee of Hammerton is authorized to make any modification or addition to this limited warranty.

TO THE FULL EXTENT ALLOWED BY LAW, THE FOREGOING WARRANTY AND REMEDIES ARE EXCLUSIVE, AND HAMMERTON EXPRESSLY DISCLAIMS ALL OTHER WARRANTIES, EXPRESSED OR IMPLIED, INCLUDING WITHOUT LIMITATION THE IMPLIED WARRANTIES OF MERCHANTABILITY AND FITNESS FOR A PARTICULAR PURPOSE. TO THE FULL EXTENT ALLOWED BY LAW, HAMMERTON EXCLUDES AND DISCLAIMS LIABILITY, WHETHER BASED IN CONTRACT OR TORT (INCLUDING NEGLIGENCE FOR ANY CONSEQUENTIAL, INDIRECT INCIDENTAL OR SPECIAL DAMAGES OF ANY NATURE ARISING OUT OF THE SALE INSTALLATION, MAINTENANCE, USE OR FAILURE OF THIS PRODUCT, EVEN IF HAMMERTON HAS BEEN ADVISED OF THE POSSIBILITY OF SUCH DAMAGES IN ADVANCE, AND HAMMERTON LIMITS ITS LIABILITY TO REPLACEMENT, REPAIR OR REFUND OF THE PURCHASE PRICE PAID, AT HAMMERTON'S OPTION.)

SOME STATES DO NOT ALLOW LIMITATIONS ON HOW LONG AN IMPLIED WARRANTY LASTS AND/OR DO NOT ALLOW THE EXCLUSION OR LIMITATION OF INCIDENTAL OR CONSEQUENTIAL DAMAGES, SO THE ABOVE LIMITATION ON IMPLIED WARRANTY AND INCIDENTAL OR CONSEQUENTIAL DAMAGES MAY NOT APPLY TO YOU. THIS WARRANTY GIVES YOU SPECIFIC LEGAL RIGHTS YOU MAY HAVE OTHER RIGHTS, WHICH VARY FROM STATE TO STATE

HAMMERTONSTUDIO™

Assembly Instructions

Double Box Post Mount

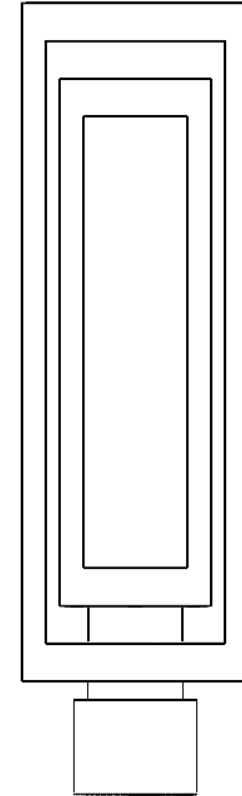

OMB0027-01

WARNING: FAILURE TO INSTALL THIS FIXTURE PROPERLY MAY RESULT IN SERIOUS PERSONAL INJURY OR DEATH AND PROPERTY DAMAGE.

It is recommended that this product be installed by a licensed electrician.

41-001-00169
Rev 3