

Collection: AXIS

Product #: CHB0060-11

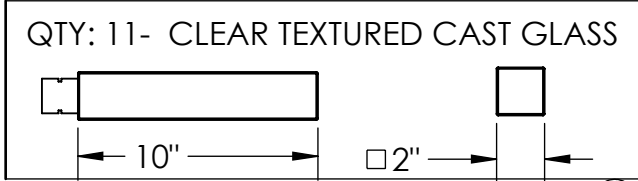
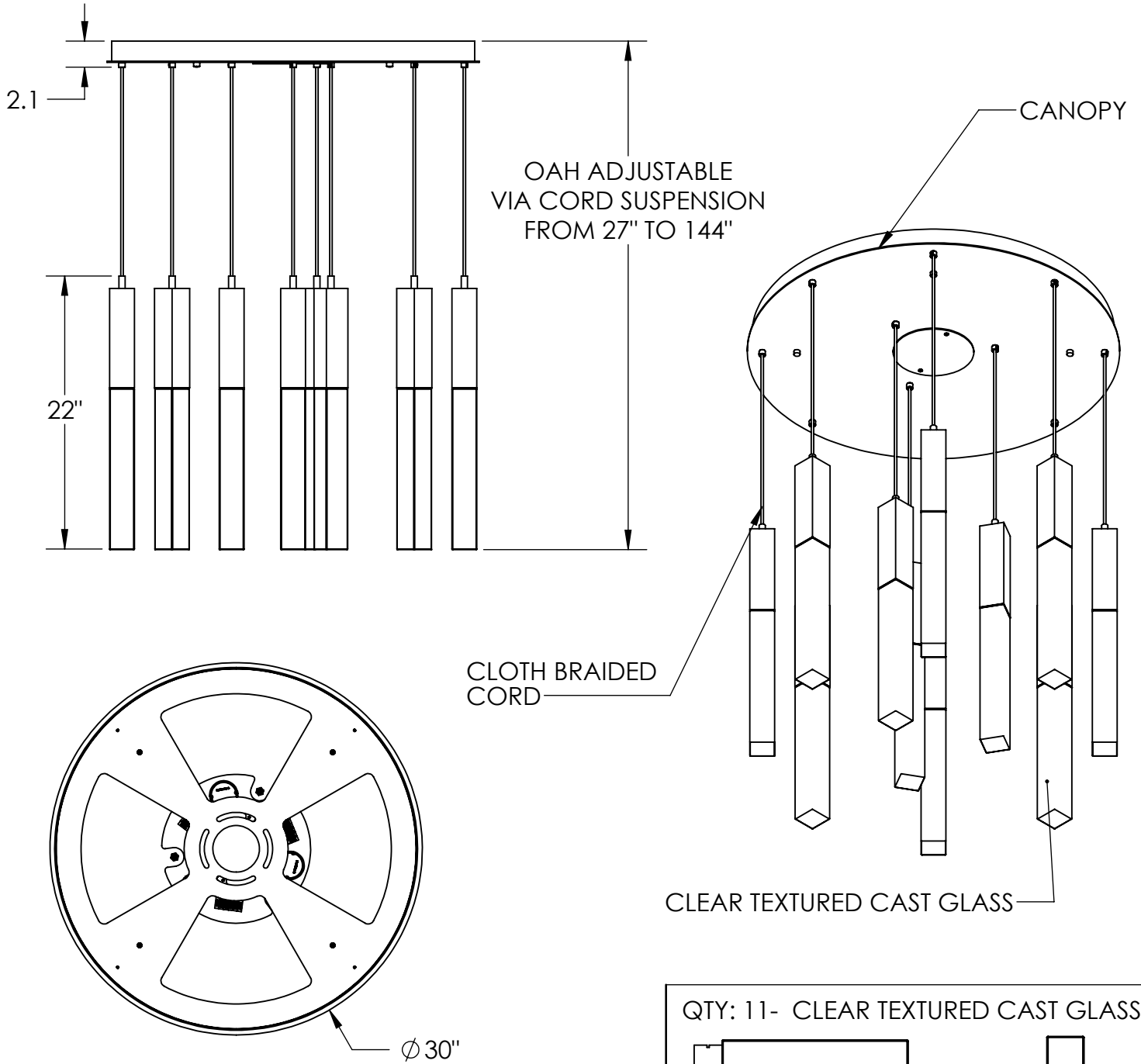

Visit hammertonstudio.com for product options and specifications.

8/9/2021 ©

Mounting Packet: R	Weight(lbs.): 105	Electrical Type: LED	CCT: 2700/3000 K
UL Location: DRY	Elec. Qty: 11	Wattage: 57	Voltage: 120
Finish: SEE WEB SITE FOR OPTIONS	Source Lumens:	Ambient:4623	Down:0
Top Diffuser: N/A	Dimmable: Forward/Reverse Phase To 1%		
Bottom Diffuser: CAST GLASS	CRI: 93+	Power Factor: >0.9	

All fixtures created by Hammerton are handcrafted by artisans. Dimensions may vary up to 7/8".

© Copyright 2021. All rights in design, detail or invention of this drawing are reserved as the property of Hammerton. Any imitation or adaptation without written consent is strictly prohibited.

Mounting Detail

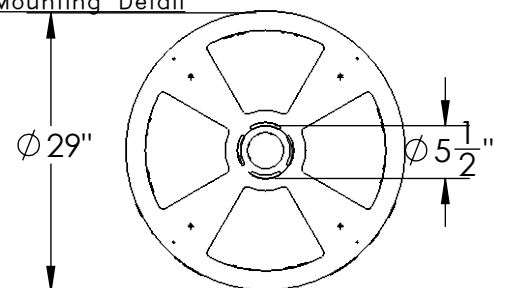

MOUNTS TO BUILDING STRUCTURE