

Included Components

- A. Hardware Packet with Instructions (Not Shown)
- B. Upper Body
- C. Lower Body
- D. Body Wraps (x4 pieces)
- E. 1/8" Spring Pins (x4 pieces)
- F. Backplate/Mounting Plate Assembly
- G. 8-32 x 0.3125" Set Screw
- H. Allen key for set screw
- I. Blown Glass
- J. #8-32 Pan Head Screws (x4 pieces)
- K. Rubber Gasket
- L. #8-32 Flat Head Screws (x4 pieces)
- M. Upper Outer Glass (x4 pieces)
- N. Lower Outer Glass (x4 pieces)
- O. #4-40 Pan Head Screws (x8 pieces)
- P. Lens Retention Bars (x8 Pieces)

Required Tools

- 1. Drill
- 2. 3/32" drill bit for pilot holes
- 3. Socket/nutdriver
- 4. Phillips screw driver

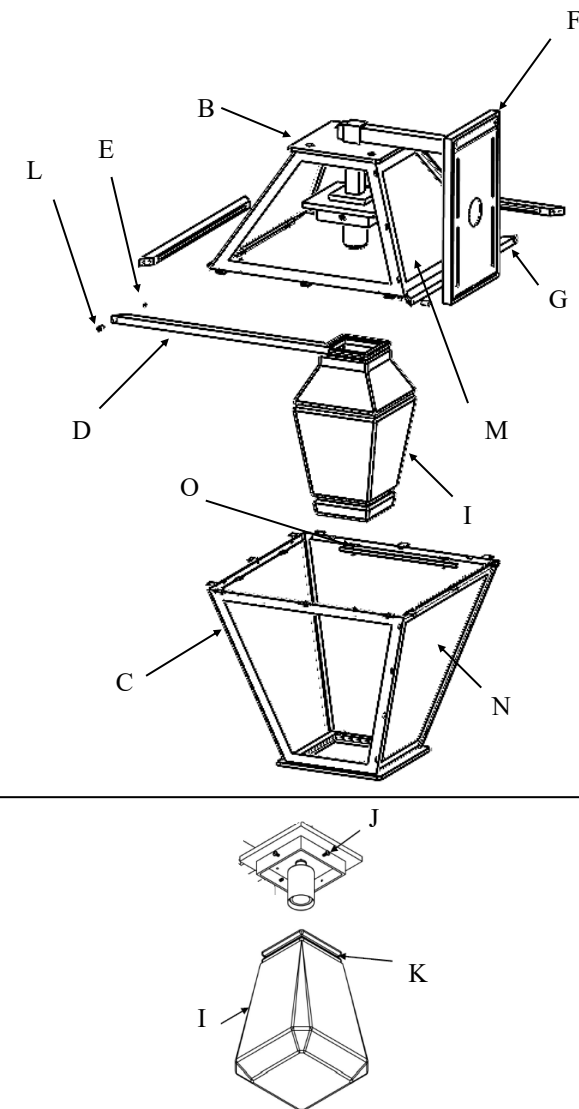

Detail of Blown Glass Assembly

Fixture Installation Overview

- Step 1:** Install outer glass
- Step 2:** Install Bulb and Blown Glass
- Step 3 :** Connect Upper Body (B) and Lower Body (C)
- Step 4 :** Connect Backplate/Mounting Assembly (F) to Lantern Body
- Step 5:** Mount Plate to building structure and make wire connections
- Step 6:** Hang fixture and install set screw

Step 1: Install Outer Glass

- a. Slide Tabs towards the center of the body
- b. Gently place Upper Outer Glass (M) into fixture and lean against the inside face of the light body
- c. Attach Lens Retention Bars (P) using #4-40 Pan Head Screws (O)
- d. Slide Tab against the edge of the Glass and secure in place by tightening screws
- e. Repeat for Lower Outer Glass (N)

CAUTION: DO NOT OVER TIGHTEN LENS RETENTION

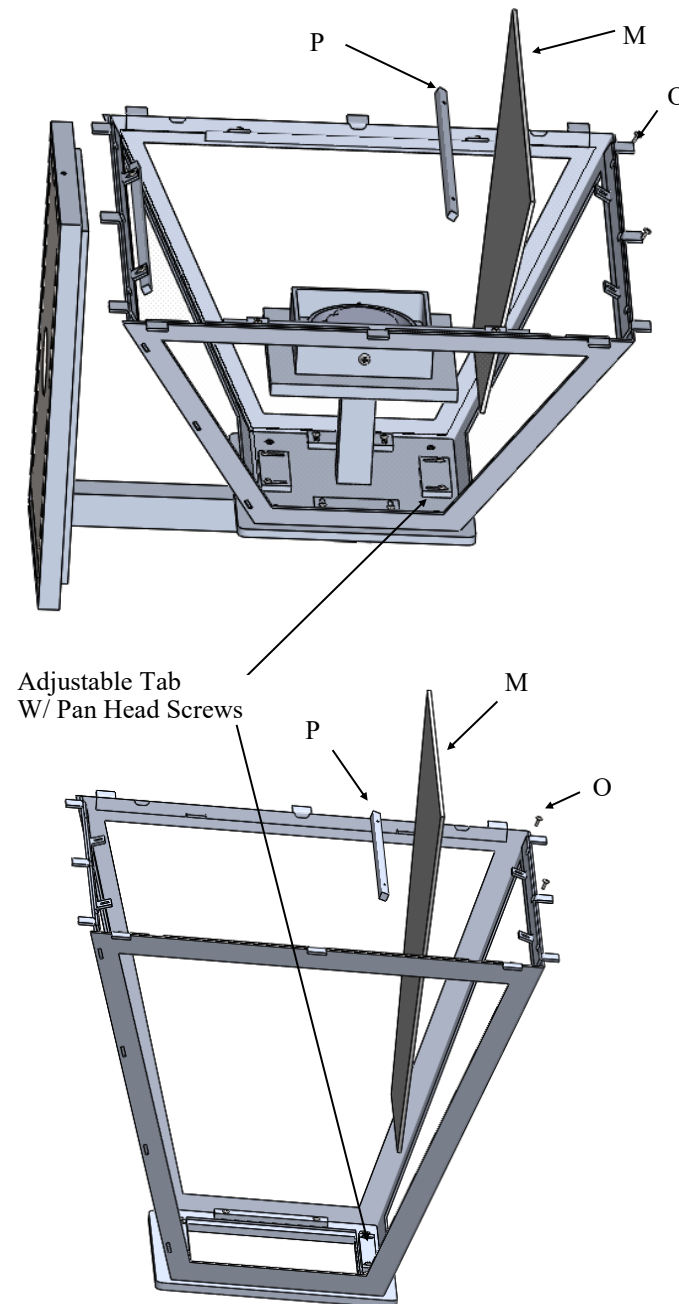

Fixture Installation Details

Step 2: Install Bulb and Blown Glass

- a. Install Lamping (bulb)
- b. Ensure Rubber Gasket (K) is installed on the top groove of the glass to prevent glass to metal contact. Not having this gasket could result in glass breaking.
- c. Install Chilled Glass. Secure in place with the four (4) pan head screws provided. Make sure the screws seat inside of the lip.

CAUTION: Tightening screw into the glass may cause the glass to break.

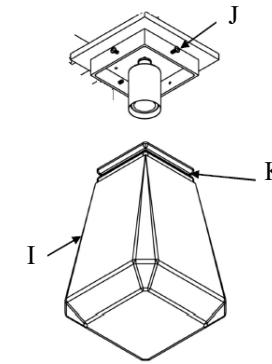

Step 3 : Connect Upper Body (B) and Lower Body (C)

- a. Set Upper Body (B) on top of Lower Body (C). Ensure both halves are facing the same direction by noting the back surfaces are aligned. The back surfaces have a lip on the seam with welds that are noticeable to help align properly, whereas the front has rounded bent corners. **See Figure A for detail image.** Slide tabs of Lower Body into Back Wrap attached to Upper body and Backplate, tilting Upper Body as shown below should help the Lower Body tabs slide into groove of wrap.

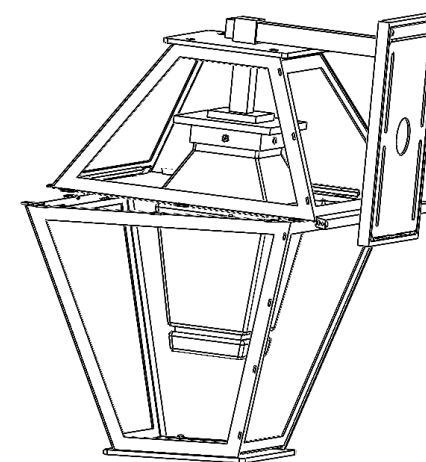
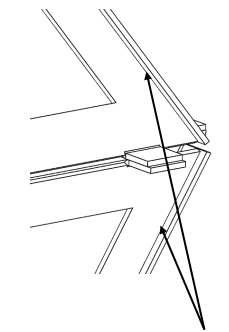

Figure A



Over lap with some visible welds helps to indicate back of fixture

Step 4: install wraps

- b. Locate the Body Wraps (D)
- c. Identify Front (x1), Sides (x2), and Rear (x1) wrap components. Shown in **Figure B**. **note: rear should be attached to backplate and Upper Body**

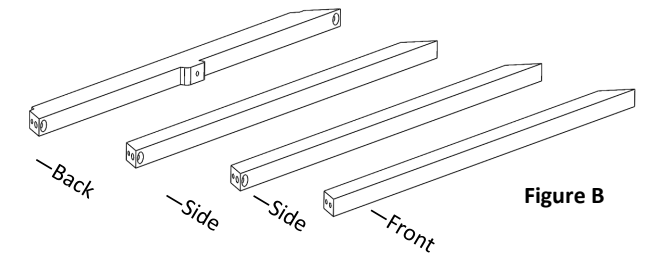

Figure B

- d. Locate 1/8" Spring Pins (E)
- e. Install Front Wrap onto fixture and center.
- f. Install x2 Side Wraps one at a time, capturing 1/8" Spring Pin (E) between two pieces as they are secured together using 8-32 flat head screw. (L) **See Figure C.**

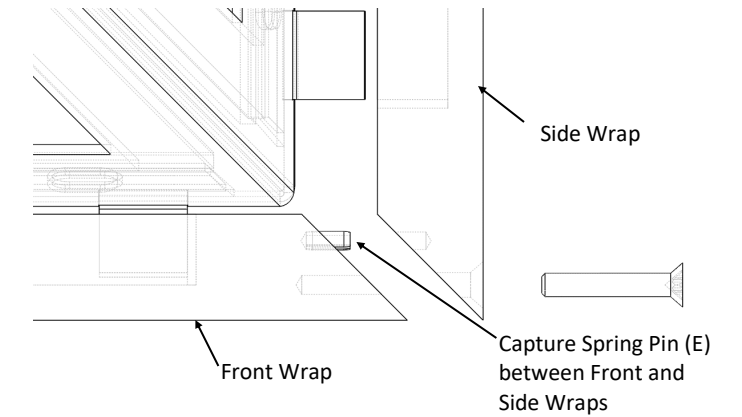

Figure C—Top View of installing Side Wrap to Front Wrap

Step 5: Follow instructions provided in Hardware Pack C to Mount Plate to building structure and make wire connections

Step 6: Hang Fixture onto mounting plate . Come from the top down at an angle to catch the tab on the plate, as shown in **Figure G and Figure H**

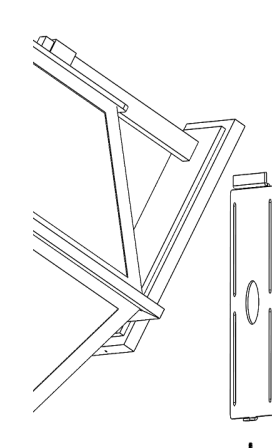

Figure G

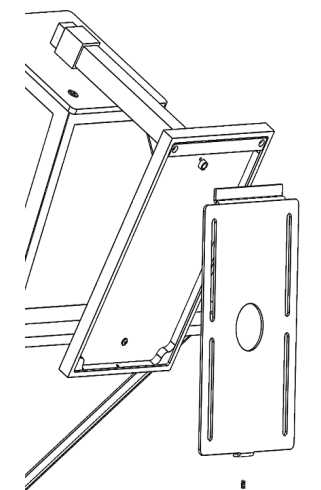

Figure H

HAMMERTON STUDIO

When we introduced the Hammerton Studio brand in 2014, we saw an enormous opportunity to raise the bar in decorative lighting. In design, we wanted to lead rather than follow. In construction, we wanted to showcase Hammerton's renowned reverence for time-honored artisan craftsmanship and authentic materials. In performance, we wanted to provide highly reliable solutions that far exceeded industry norms for aesthetics, function, and quality. Based on the brand's dramatic growth and customer feedback, it's clear we are on the right track.

EXTRAORDINARY DESIGN VALUE IN ARTISAN GLASS & METALWORK

Hammerton began in 1995 as a blacksmith shop, but we've come a long way since then. Today we employ a world class team of metal artisans who are disciplined in a broad range of fabrication techniques and processes. We've also added in-house capabilities in blown, cast and kiln-fused glass, and today Hammerton operates one of the largest artisan glass production facilities in the U.S. With deep design and fabrication expertise at the intersection of glass and metalwork, we're laying the foundation for a new era of lighting innovation.

THE HAMMERTON HERITAGE

Our Hammerton Studio brand stands on the shoulders of more than a quarter century of experience pushing the boundaries of innovative custom lighting design. Each Hammerton Studio collection has been inspired by custom work our company has brought to life in collaboration with leading interior design professionals over the years. Built to your specifications, every fixture reflects the uncompromising design and attention to detail that is distinctly Hammerton.

A REPUTATION REFLECTED BY OUR CLIENTS

Hammerton fixtures are as extraordinary as the clients who purchase them, including Forbes 400 members, Fortune 500 leaders, award-winning entertainers, fashion and interior designers, sports legends, and leading luxury hospitality brands.

Hammerton Inc.
217 Wright Brothers Drive
Salt Lake City, UT 84116

801-973-8095
info@hammerton.com
www.hammerton.com

ONE YEAR LIMITED WARRANTY

Hammerton, Inc. (Hammerton) warrants the original owner that this product will be free of defects in material or workmanship for the period of one year from the date of original purchase from Hammerton, if (i) the allegedly defective product has not been abused, misused or improperly maintained and or repaired during the warranty period, (ii) the defect is not caused by water damage/flooding, fire, explosion, earthquakes or similar phenomenon, and (iii) the defect is not caused by improper installation (unless installed by Hammerton).

In order to obtain warranty service, the user must first complete a warranty claims form. Hammerton will determine if the product will be inspected on site or returned to Hammerton. If after the inspection Hammerton finds that the product is defective as claimed, Hammerton will, at its option, repair or replace the product free of charge, or Hammerton may also agree to outsource necessary repair work locally using local contracted labor. Prior to any outsourcing of repair work regarding this fixture, a Work Authorization Form must be signed by both the client and Hammerton Representative. Failure to do so may result in a denial of reimbursement. Hammerton warrants any replaced or repaired products for ninety days after shipment or through the end of the original warranty period, whichever is longer. All products or parts that are replaced become the property of Hammerton.

No representative or employee of Hammerton is authorized to make any modification or addition to this limited warranty.

TO THE FULL EXTENT ALLOWED BY LAW, THE FOREGOING WARRANTY AND REMEDIES ARE EXCLUSIVE, AND HAMMERTON EXPRESSLY DISCLAIMS ALL OTHER WARRANTIES, EXPRESSED OR IMPLIED, INCLUDING WITHOUT LIMITATION THE IMPLIED WARRANTIES OF MERCHANTABILITY AND FITNESS FOR A PARTICULAR PURPOSE. TO THE FULL EXTENT ALLOWED BY LAW, HAMMERTON EXCLUDES AND DISCLAIMS LIABILITY, WHETHER BASED IN CONTRACT OR TORT (INCLUDING NEGLIGENCE FOR ANY CONSEQUENTIAL, INDIRECT INCIDENTAL OR SPECIAL DAMAGES OF ANY NATURE ARISING OUT OF THE SALE INSTALLATION, MAINTENANCE, USE OR FAILURE OF THIS PRODUCT, EVEN IF HAMMERTON HAS BEEN ADVISED OF THE POSSIBILITY OF SUCH DAMAGES IN ADVANCE, AND HAMMERTON LIMITS ITS LIABILITY TO REPLACEMENT, REPAIR OR REFUND OF THE PURCHASE PRICE PAID, AT HAMMERTON'S OPTION.)

SOME STATES DO NOT ALLOW LIMITATIONS ON HOW LONG AN IMPLIED WARRANTY LASTS AND/OR DO NOT ALLOW THE EXCLUSION OR LIMITATION OF INCIDENTAL OR CONSEQUENTIAL DAMAGES, SO THE ABOVE LIMITATION ON IMPLIED WARRANTY AND INCIDENTAL OR CONSEQUENTIAL DAMAGES MAY NOT APPLY TO YOU. THIS WARRANTY GIVES YOU SPECIFIC LEGAL RIGHTS YOU MAY HAVE OTHER RIGHTS, WHICH VARY FROM STATE TO STATE

Assembly Instructions

Large Outdoor Lantern Internal Blown Glass

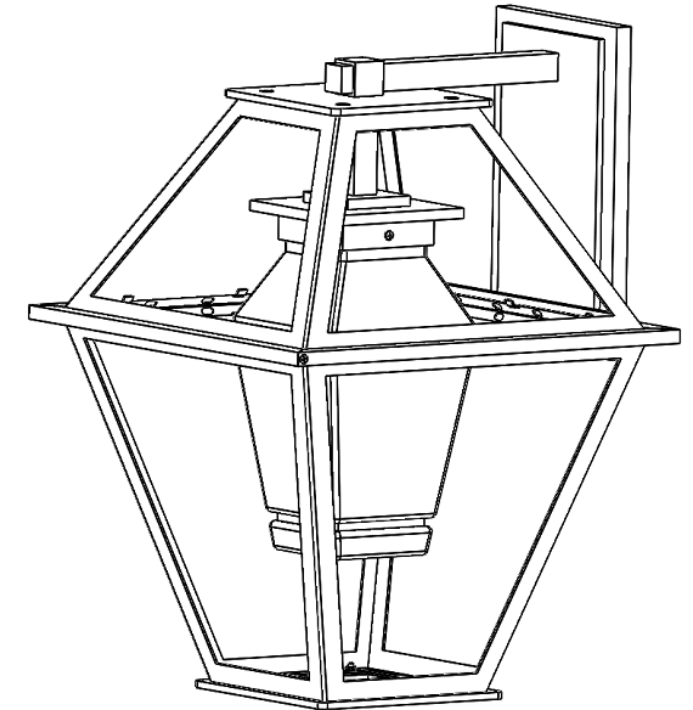

ODB0043-AJ-E2

WARNING: FAILURE TO INSTALL THIS FIXTURE PROPERLY MAY RESULT IN SERIOUS PERSONAL INJURY OR DEATH AND PROPERTY DAMAGE.

WARNING: MUST USE MANUFACTURER SPECIFIED BULB. USING ANY OTHER TYPE OR WATTAGE BULB MAY CAUSE DAMAGE TO THE FIXTURE AND CREATE A POTENTIAL FIRE HAZARD.

It is recommended that this product be installed by a licensed electrician.