

Collection: COPPA

Product #: CHB0036-05

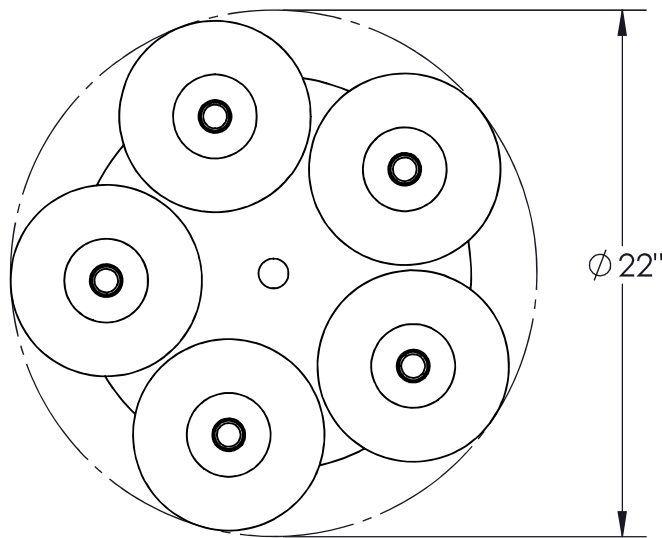
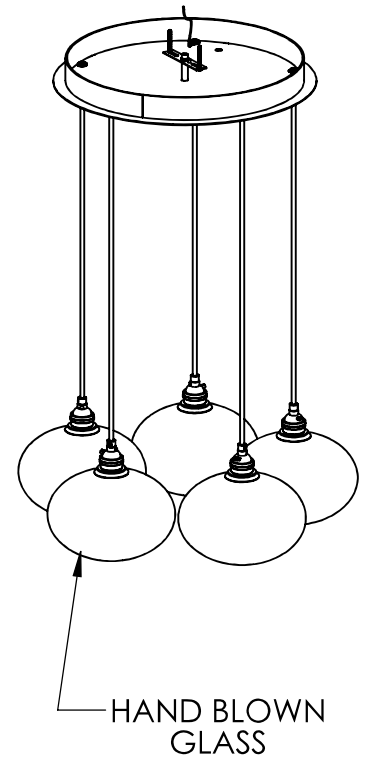
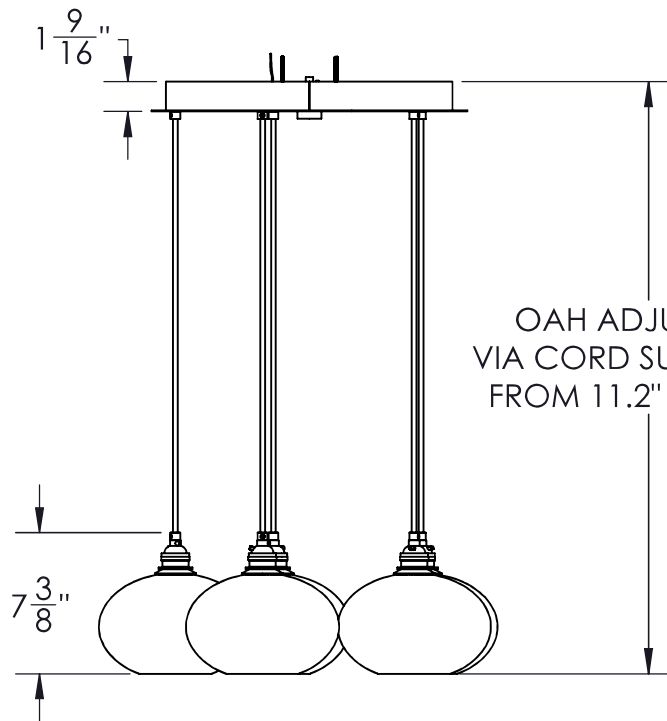

HANDBLOWN GLASS DIMENSIONS
MAY VARY ± 1 "

QTY: 5

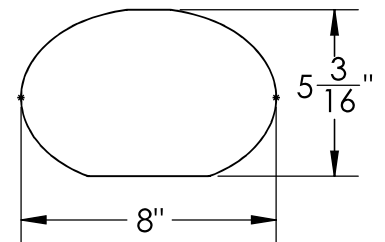

All dimensions are shown in inches unless otherwise stated.
Visit hammertonstudio.com for product options and specifications.

Bulbs Not Included

Mounting Packet: W	Electrical Type: INCANDESCENT
Approximate lbs.: 22	Bulb Qty: 5 Bulb Type: A19
Finish: SEE WEB SITE FOR OPTIONS	Wattage: 40 Voltage: 120
Top Diffuser: N/A	Socket Type: E26
Bottom Diffuser: OPEN	UL Location: DRY

Mounting Detail

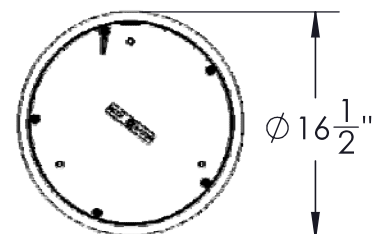

All fixtures created by Hammerton are handcrafted by artisans. Dimensions may vary up to 7/8".

© Copyright 2021. All rights in design, detail or invention of this drawing are reserved as the property of Hammerton. Any imitation or adaptation without written consent is strictly prohibited.

Hammerton Inc. 217 Wright Brothers Dr. Salt Lake City, UT 84116 (801)973-8095

MOUNTS DIRECTLY TO J-BOX